

CHINVAY

APPROVAL SHEET

CUSTOMER :

ITME : D 型混装大电流连接器

MODEL : DMP0-17W2S-03

MATERIEL NO:

DATE : 08/08/2007

APPROVED BY:

深圳市创宇伟业科技有限公司

地 址： 深圳市龙岗区葵冲镇奔康工业区 B-7 栋 3 楼

电 话： 0755-8977 3388 8312 0030

传 真： 0755-8312 0032 8977 5511

网 站： www.chinvay.com

阿里巴巴： cywy01.cn.alibaba.com

销售经理： 胡先生 手机： 136 0251 1930

邮 件 I： hkn@chinvay.com

邮 件 II： hukn999@163.com

REV.	ECN NO.	LOCATION	DESCRIPTION	DATE	DESIGN
V0.0			初版发行	2007/0808	

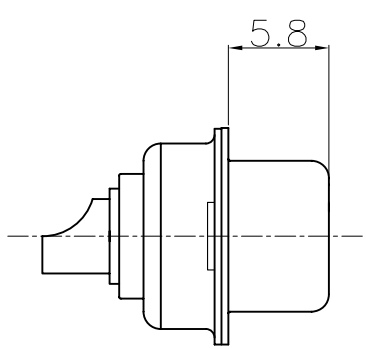
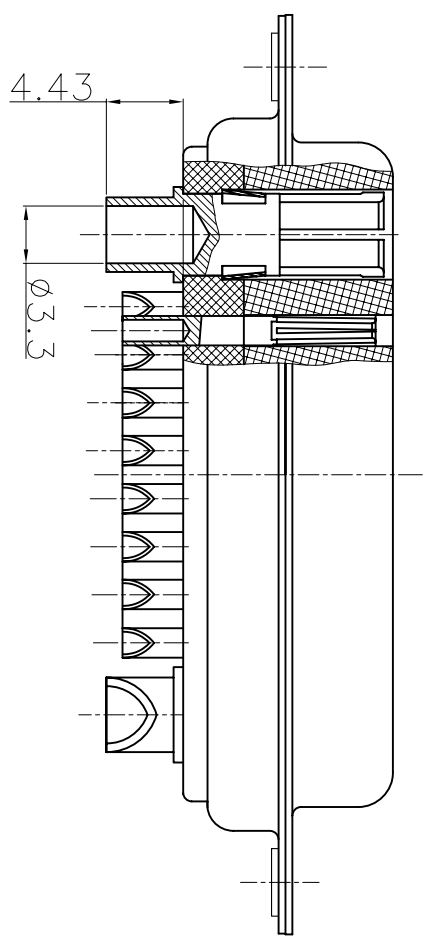
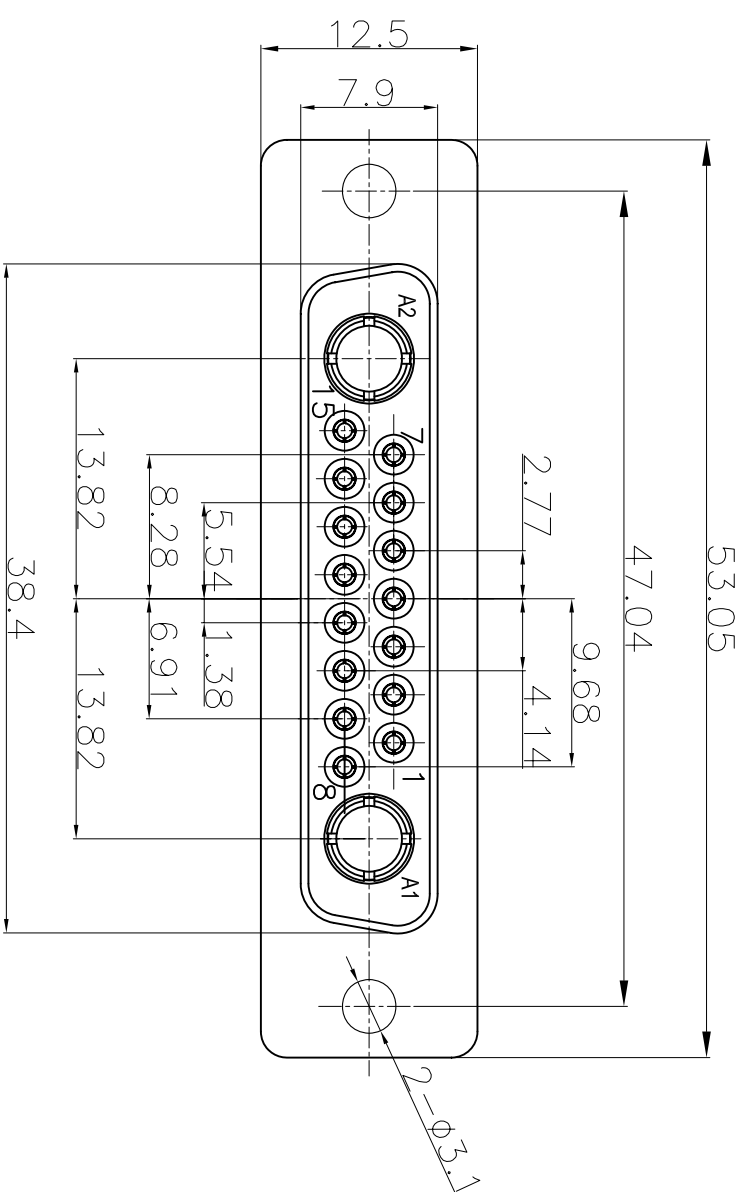

NOTES:

- Material :
Housing: PBT301-G30 UL94V-0, Black
Contact: Copper Alloy Gold plating
Shell: Spec Ni plating
- ACCORD WITH "ROHS".
- Electrical performances
Rated current: For heavy current contact 30A ,
For signal contact 5A
Contact resistant: For heavy current contact $\leq 5m\Omega$,
For signal contact $\leq 10m\Omega$
Insulation resistant: $\geq 1000M\Omega$
Withstand voltage: AC 1000V/1min
- Mechanical performances
Range: $-55\sim 105^{\circ}C$ Lift test: 500 cycles

DIM	TOL	DIM	TOL
x	± 0.1	x	$\pm 2^{\circ}$
.x	± 0.1	.x	
.xx	± 0.1	.xx	
.xxx		.xxx	

		深圳市创宇伟业科技有限公司	
FILE NO.	DATE	TITLE: D型(15+2)芯短接线插头 (孔)	P/N: DMP0-17W2S-03
DESIGN:	CHECK:		SHEET: 1/1
REV.	APPROVAL:		SCALE: 1:1
V0.0			UNIT: mm

一.	Material NO 物料代码:
二.	Material Name 物料名称: D 型混装 (15+2) 芯短焊线插头 (孔)
三.	Product Type 产品型号: DMP0-17W2S-03
<p>四. Technical features 技术参数:</p> <div style="float: right; text-align: center;">  </div> <p>1. Electric characteristic 电气特性</p> <p>1.1 Rated current 额定电流: For heavy current contact 大电流接触件 30A For Signal contact 信号接触件 5A</p> <p>1.2 Rated voltage 额定电压: 250V</p> <p>1.3 Insulation resistance 绝缘电阻: $\geq 1000M \Omega$</p> <p>1.4 Voltage proof 耐电压: 1000V AC</p> <p>1.5 Contact resistance 接触电阻: For heavy current contact 大电流接触件 $\leq 5 m \Omega$ For Signal contact 信号接触件 $\leq 10 m \Omega$</p> <p>2. Mechanical characteristic 机械特性</p> <p>Mating Force 插入力: For heavy current contact 大电流接触件 $\leq 5.0N$ For Signal contact 信号接触件 $\leq 2.0N$</p> <p>Unmating Force 分离力: For heavy current contact 大电流接触件 $\geq 1.0N$ For Signal contact 信号接触件 $\geq 0.6N$</p> <p>Mechanical Durability 机械寿命: 500cycles 500 次</p> <p>3. Material and surface plating 材料及表面处理</p> <p>3.1 Contact 接触件 Material 材料: phosphorous bronze 青铜 Production Technique 生产工艺: For heavy current contact 大电流接触件 Turing 车削加工 For Signal contact 信号接触件 Punching 冲压加工</p> <p>Surface plating 表面处理: For heavy current contact: Plating 5u" Gold over Nikel 大电流接触件镀金 5u", For Signal contact: Contact area Plating 5u", Gold over Nikel, other area Plating Sn voer Nikel 接触区域镀金 5u", 其余镀纯锡</p> <p>3.2 Housing 基座 Material 材料: PBT, With GF, UL 94V-0 Black Production Technique 生产工艺: Injecting 注塑加工</p> <p>3.3 Sheel 外壳 Material 材料: Steel Strip 钢带 Production Technique 生产工艺: Punching 冲压加工 Surface plating 表面处理: Plating Ni 镀镍</p> <p>4. Environment 工作环境</p> <p>Temperature range 工作温度: $-55^{\circ}C \sim 105^{\circ}C$ Ralative humidity 相对湿度: $40^{\circ}C$时, (90-95) %</p>	

Vibration 振动: 10Hz~2000Hz, Acceleration 加速度 196m/s^2

Shock 冲击: Acceleration 490m/s^2

五. **Most figure size 最大外型尺寸:** $53 \times 12.5 \times 15.6$

六. **Material introduction 物料简介:**

1. Basic instance 基本情况

The design of electrical features and Mechanical features is based on IEC60807-2.

电性能和机械性能依据 IEC60807-2、IEC60603-2 标准进行设计。

The connector is socket of Series D Rectangular Connector. Its terminal method is wire jointing, it could be applied with DMP-17W2P.

该连接器为 D 系列矩形混装插头，端接方式为导线焊接，可与 DMP-17W2P 配合使用。

2. Pack and Storage 包装储存

Products are Packed with plastic box. The packing list must be in the packing box which has been gave clear indication of designation、type、lot number and products total number.

The products with packing are saved up at storeroom which environment temperature is $5^{\circ}\text{C} \sim 30^{\circ}\text{C}$, humidity $\leq 80\%$, no acidity、no alkalescence and other corrosive gas, under these conditions the stockpile period doesn't exceed tow years from production date.

产品采用吸塑盒包装，箱内应有装箱单，装箱单及包装箱上注明产品名称、型号、批号及产品总数量。

包装好的产品应放环境温度为 $5^{\circ}\text{C} \sim 30^{\circ}\text{C}$ ，相对湿度在 80% 以下，周围空气中无酸性、碱性或其他腐蚀性气体的库房里储存，在上述条件下，储存期自生产日期不超过两年。

3. **In point criterion 适用标准:** IEC60807-2

4. **Technique use 工艺使用:**

Wire jointing 导线焊接