

# CHINVAY

## APPROVAL SHEET

CUSTOMER :

ITME : 6PIN 方型 SIM 卡座

MODEL : SC-2.54-XX-6C15SMT

MATERIEL NO:

DATE : 08/08/2007

APPROVED BY:

### 深圳市创宇伟业科技有限公司

地 址： 深圳市龙岗区葵冲镇奔康工业区 B-7 栋 3 楼

电 话： 0755-8977 3388 8312 0030

传 真： 0755-8312 0032 8977 5511

网 站： [www.chinvay.com](http://www.chinvay.com)

阿里巴巴： [cywy01.cn.alibaba.com](http://cywy01.cn.alibaba.com)

销售经理： 胡先生 手机： 136 0251 1930

邮 件 I： [hkn@chinvay.com](mailto:hkn@chinvay.com)

邮 件 II： [hukn999@163.com](mailto:hukn999@163.com)

REV.	ECN NO.	LOCATION	DESCRIPTION	DATE	DESIGN
VO.1			初版发行	10/06/07	

**NOTES:**

1. MATERIAL SEE TABLE;
2. ALL DIMENSIONS ARE IN MILLIMETERS;
3. ELECTRICAL PERFORMANCES:
  - 3.1 CURRENT RATING: 0.5A Max;
  - 3.2 VOLTAGE RATING: 30V AC;
  - 3.3 INSULATION RESISTANCE: 100MGA OHMS MIN;
  - 3.4 DIELECTRIC WITHSTANDING VOLTAGE: 250V AC
- FOR 1 MINUTE;
- 3.5 CONTACT RESISTANCE: 50 MILLI OHMS MAX;
4. MECHANICAL PERFORMANCES:
  - 4.1 CONTACT NORMAL FORCE: SEE TABLE;
  - 4.2 DURABILITY: 5000 CYCLES;
  - 4.3 OPERATING TEMPERATURE: -40° TO +85°;
- 4.1 CONTACT NORMAL FORCE: SEE TABLE;
- △ CONNECTOR LOCATION PROFILE;
6. (Z) CRITICAL DIMENSION;
- △ COPPLANARITY OF SOLDER PINS: 0.10HMM MAX;
- △ PICK UP AREA;

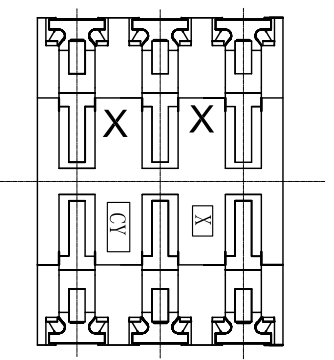
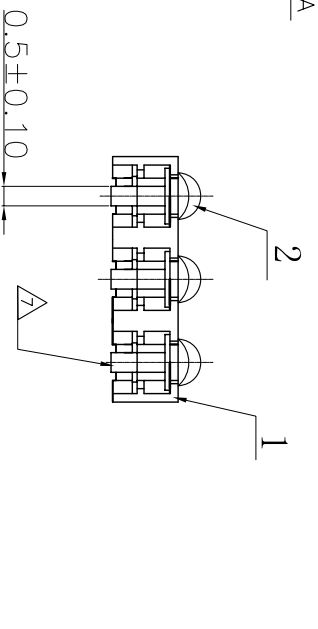
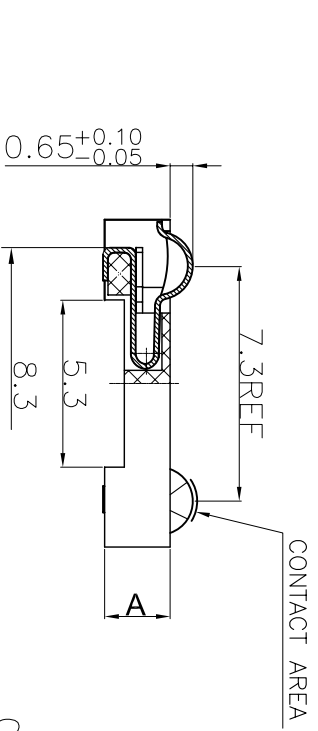
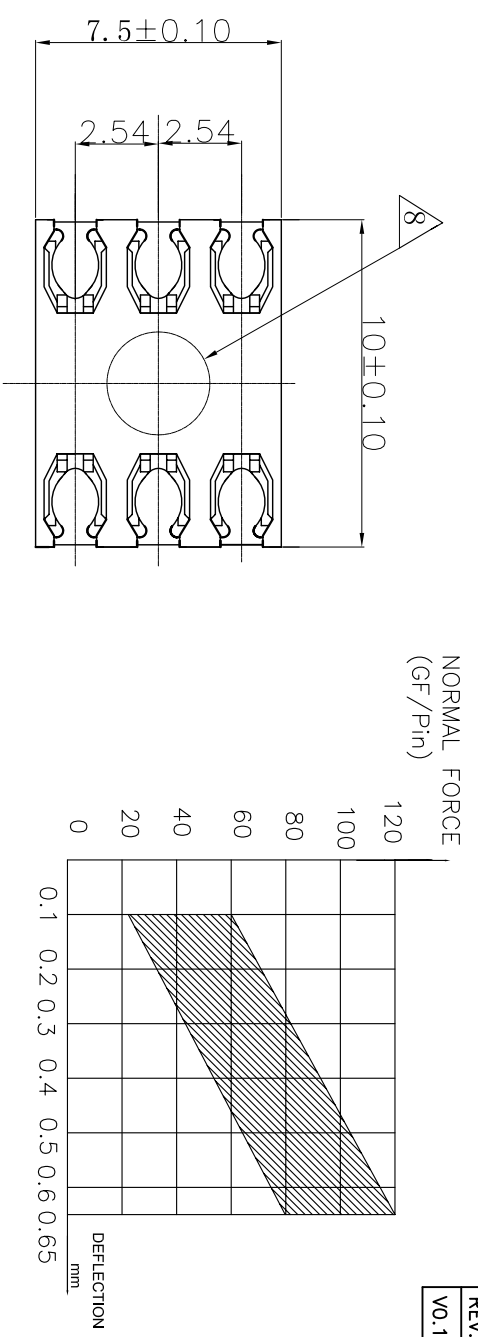

**RECOMMENDED PCB LAYOUT**

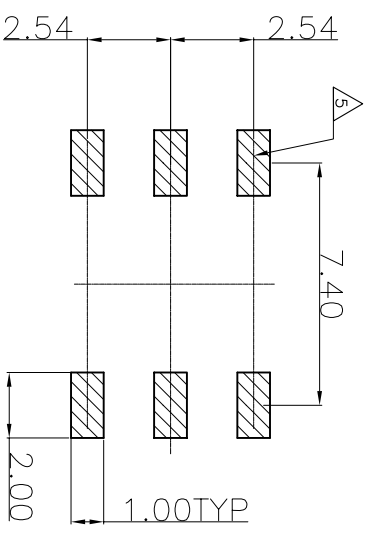

MATERIAL NO:	MODEL	A
3020059-14	SC-2.54-1.4-6C15SMT	1.4
3020059-15	SC-2.54-1.5-6C15SMT	1.5
3020059-16	SC-2.54-1.6-6C15SMT	1.6
3020059-17	SC-2.54-1.7-6C15SMT	1.7
3020059-18	SC-2.54-1.8-6C15SMT	1.8
3020059-19	SC-2.54-1.9-6C15SMT	1.9
3020059-20	SC-2.54-2.0-6C15SMT	2.0
3020059-21	SC-2.54-2.1-6C15SMT	2.1
3020059-22	SC-2.54-2.2-6C15SMT	2.2
3020059-23	SC-2.54-2.3-6C15SMT	2.3
3020059-24	SC-2.54-2.4-6C15SMT	2.4
3020059-25	SC-2.54-2.5-6C15SMT	2.5

ITEM	DESCRIPTION	MATERIAL	Q'TY	REMARKS
2	CONTACT	COPPER ALLOY GOLD PLATING 15u" ON CONTACT AREA, GOLD FLASH AT SOLDER AREA, 50" MIN NICKEL UNDERPLATING OVERALL	6	
1	HOUSING	THERMOPLASTIC UL94V-0 COLOR BLACK	1	

DIM	TOL	DIM	TOL
X	±0.15	X	±2°
.X	±0.10	X	±1°
.XX	±0.05	.XX	±1°
.XXX	±0.01	.XXX	±1°

**深圳市创宇伟业科技有限公司**

© ILLUMINANT

FILE NO.	DATE	TITLE: SIM CARD CONNECTOR
DESIGN:		P/N: SC-2.54-XX-6C15SMT
CHECK:		SHEET: 1/1
REV.	VO.1 APPROVAL:	SCALE: 1:1 UNIT: mm

SC-2.54-XX-6C15SMT

Sim card  
Pitch header  
Housing height

Connection type  
Gold Plating 15u"  
Position



# 规格书

系列类型	SIM CARD CONNECTOR	编写 WRTN BY:	审核 CHECKED BY	批准 APPROVED BY
型号	SC-2.54-XX-6C15SMT	CHEN MING	ZHANG BO	WANG WEI
VERSION 版本:	V0.1			
DATE 日期:	2007.10.24	2007.10.23	2007.10.23	2007.10.24

1. SCOPE 适用范围 本规格书适用:“SIM CARD CONNECTOR”系列 This specification covers the requirements for: “SIM CARD CONNECTOR”

2. Rating 额定值: DC 30V 0.5A

3. CONSTRUCTION 构造

3.1 Shape and dimensions are subject to drawing. 形状.尺寸根据图面确定.

3.2 All part not allowed to exist rust 、 crack and poor planting.各部分无生锈、裂痕、电镀不良现象.

4. Standard test conditions shall be 5 to 35°C in temperature and 45 TO 85% in humidity.

温度 5~35°C , 湿度 45~85% 标准状态下测试。

Item 项目	Test condition 测试条件	Performance 规格
---------	---------------------	----------------

5. Electrical performance 电气性能

5.1	Contact resistance 接触阻抗	Being measured at 1 KHz small current contact resistance meter. 在 1kHz 小电流下测量。	50mΩ max. 50 毫欧 以下。
5.2	Insulation resistance 绝缘阻抗	Measurements shall be made following application of DC 500 V potential across terminals and across terminals and frame for 1 minute. 在端子之间和端子与壳之间加 DC 500 V 条件下,持续 1 分钟测量。	100MΩ min. 100 兆欧 以上。
5.3	Withstand voltage 耐电压	AC 250 V(50Hz or 60 Hz)shall be applied across terminals and across terminals and frame for one minute. 在端子之间和端子与壳之间加 AC 250 V (50Hz 或 60Hz)条件下,持续 1 分钟测量。	There shall be no breakdown 无击穿现象出现.

6. Mechanical performance 机械性能

6.1	Operating force 接触压力		40gf MIN 40gf 以上
6.2	Range 使用温度范围	在-40~+85°C温度内使用	

7. Durability 耐久性

7.1	Lift test 寿命试验	5,000 cycles of operation at a rate of 15-18 cycles per minute with unloading 在无负载条件下,以每分钟 15—18 次的速度操作 5,000 次。	(1) Contact resistance 接触阻抗 200mΩ max.200 毫欧 以下 (2) 其它满足机械,电器性能.
7.2	Heat test 耐热试验	85±2°C for 96 hours, test after keeping in normal condition for 60 minutes. 在 85±2°C环境中放 96 小时,再放在正常环境中,60 分钟后进行测试。	Insulation resistance 50M Ω min.50 兆欧以上,其它满足机械,电器性能.
7.3	Humidity test 耐湿试验	40±2°C 90-95%RH for 96 hours, test after keeping in normal condition for 60 min. 在 40±2°C 90—95%RH 环境中放 96 小时,再放在正常环境中,60 分钟后进行测试。	Insulation resistance 50M Ω min.50 兆欧以上,其它满足机械,电器性能.

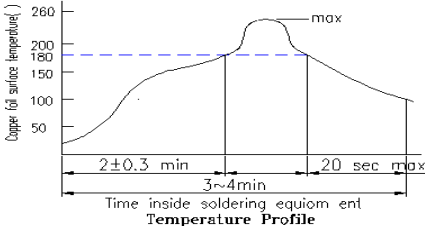
7.4	Cold test 耐冷试验	At $-25 \pm 3^{\circ}\text{C}$ for 96 hours, test after keeping in normal condition for 60 min. 在 $-25 \pm 3^{\circ}\text{C}$ 环境中放 96 小时, 再放在正常环境中, 60 分钟后进行测试。	There shall be no sign of damage mechanically and electrically 无任何迹象显示机械及电气性能损坏。
7.5	Resistance to soldering heat test 耐焊性试验	<p>soldering iron method: Bit temperature <math>350 \pm 10^{\circ}\text{C}</math> application time <math>3 \pm 0.5</math> sec application time <math>3 \pm 0.5</math> sec. However excessive pressure shall not be applied to the terminal. 手焊接的时候温度需控制在 <math>350 \pm 10^{\circ}\text{C}</math>, 时间为 <math>3 \pm 0.5</math> 秒, 不能在排脚上施加异常压力。</p> <p>Reflow Soldering Conditions: Preheat: Temperature on the copper foil surface should reach <math>180^{\circ}\text{C}</math>. <math>2 \pm 0.3</math> minutes after the P.W.B entered into the soldering equipment. Soldering heat: Temperature on the copper foil surface should reach the peak temperature of <math>240 \pm 5^{\circ}\text{C}</math> with in 20 seconds after the P.W.B enter into soldering heat zone. 过回流焊条件: 预热: 电镀层表面的温度应达到 <math>180^{\circ}\text{C}</math>, <math>2 \pm 0.3</math> 分钟, 后电路板进入回流焊设备. 回流焊温度: 电镀层表面温度最高为 <math>240 \pm 5^{\circ}\text{C}</math> 且停留不超过 20 秒后电路板进入低温焊接处.</p>  <p>The graph is titled 'Temperature Profile' and plots 'Copper foil surface temperature (°C)' on the y-axis (ranging from 50 to 280) against 'Time inside soldering equipment' on the x-axis. A horizontal dashed line is drawn at 180°C. The curve starts at approximately 50°C, rises to 180°C within a time interval of <math>2 \pm 0.3</math> min. It then continues to rise to a peak labeled 'max' at <math>240 \pm 5^{\circ}\text{C}</math>, which is maintained for a duration of 20 sec max. Finally, the temperature decreases. The total time for the entire process is indicated as 3~4 min.</p>	Without deformation of case or excessive looseness of terminals electrical characteristics shall be satisfied. 本体无变形, 能满足于机械、电气性能。