

CHINVAY

APPROVAL SHEET

CUSTOMER :

ITME : 3PIN 电池连接器

MODEL : BC-3.1-3CG3SMT

MATERIEL NO:

DATE : 08/08/2007

APPROVED BY:

深圳市创宇伟业科技有限公司

地 址： 深圳市龙岗区葵冲镇奔康工业区 B-7 栋 3 楼

电 话： 0755-8977 3388 8312 0030

传 真： 0755-8312 0032 8977 5511

网 站： www.chinvay.com

阿里巴巴： cywy01.cn.alibaba.com

销售经理： 胡先生 手机： 136 0251 1930

邮 件 I： hkn@chinvay.com

邮 件 II： hukn999@163.com

REV.	ECN NO.	LOCATION	DESCRIPTION	DATE	DESIGN
VO.1			初版发行	2007/09/07	

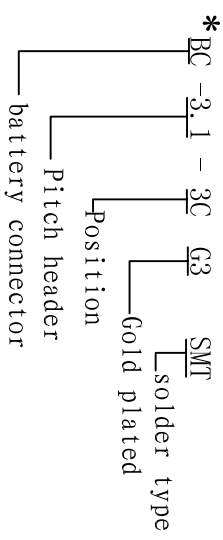
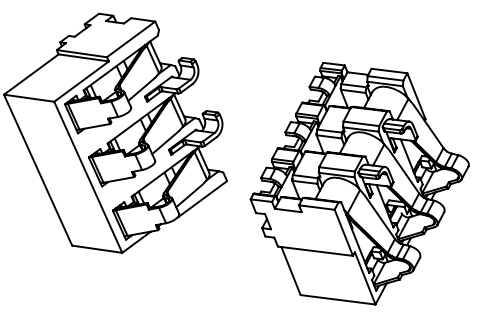
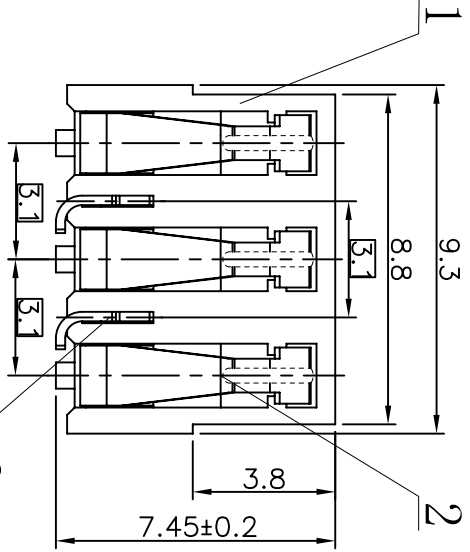
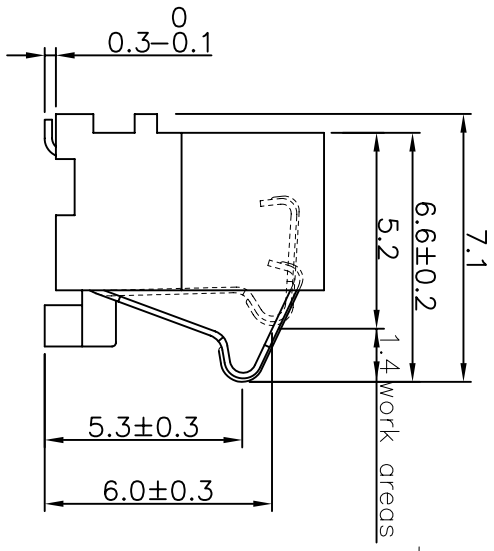
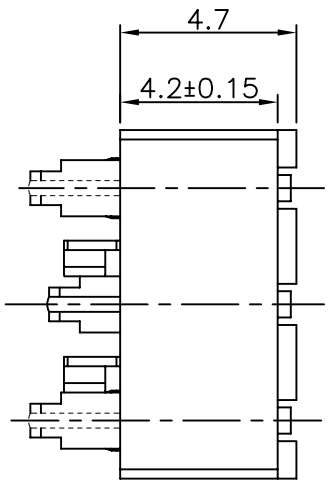

NOTES:

1. Material and finishing see table.
2. All dimensions are in millimeters.
3. Electrical performances
Rating: AC 30V 2.0A MAX
Contact resistant: 20mΩ MAX
Insulation resistant: 100MΩ
Withstand voltage: AC 250V 1min
4. Mechanical performances
Range: -40 ~85°C
Operation force: 40gf min
Lift test: 5000 cycles

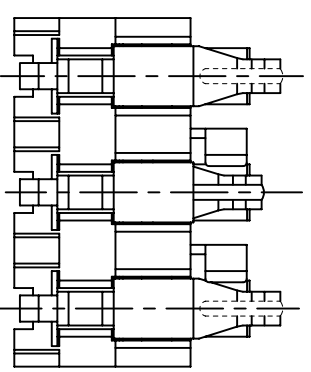
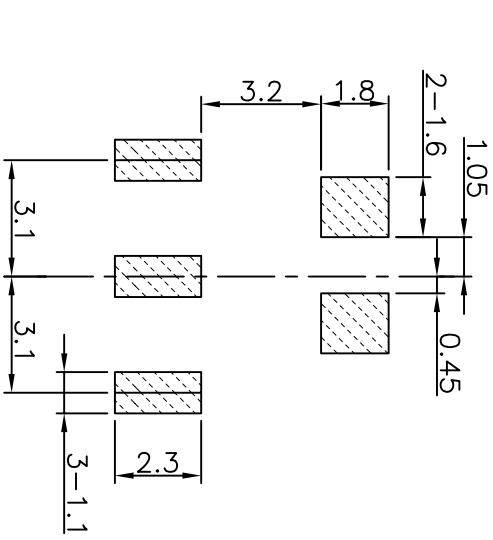

序号	代码	名称	材料及表面处理	数量	备注
3	7300013	固定片	1#2英制半硬 镀银100μ"	2	
2	5110029	接触簧片	QSN6.5-0.1 1/2半硬 镀层镀银100μ" 接触区域镀金15μ",其余11μ"	3	
1	6010035	底座	LCP, UV94-0, BLACK COLOR	1	

DIM	TOL	DIM	TOL
x	±0.20	x	±2°
.x	±0.15	.x	
.xx	±0.05	.xx	
.xxx		.xxx	

深圳市创宇伟业科技有限公司

◎ **UNIVOT**

FILE NO. _____ DATE _____

DESIGN: _____

CHECK: 3020055

REV. VO.1 APPROVAL: _____

TITLE: BATTERY CONNECTOR

P/N: BC-3.1-3CG3SMT

SHEET: 1/1

SCALE: 1:1

UNIT: mm

RECOMMENDED PCB LAYOUT

系列类型	BATTERY CONNECTOR	编写 WRTN BY:	审核 CHECKED BY	批准 APPROVED BY
型号	BC-3. 1-3CG3SMT	Wei Ming	Zhang BO	Wang Wei
VERSION 版本:	V0.1			
DATE 日期:	2007.10.16	2007.10.16	2007.10.16	2007.10.16

1. SCOPE 适用范围
 This specification covers the requirements for: "BATTERY CONNECTOR"
 本规格书适用: "BATTERY CONNECTOR" 系列

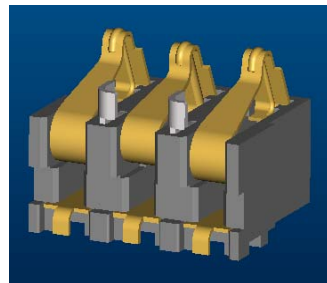

2. Rating 额定值: DC 12V 2.0A

3. CONSTRUCTION 构造

3.1 Shape and dimensions are subject to drawing.
 形状.尺寸根据图面确定.

3.2 All part not allowed to exist rust 、 crack and poor planting.
 各部分无生锈、裂痕、电镀不良现象.

4. Standard test conditions shall be 5 to 35°C in temperature and 45 TO 85% in humidity.
 温度 5~35°C , 湿度 45~85% 标准状态下测试。

5. Electrical performance 电气性能

Item 项目	Test condition 测试条件	Performance 规格
5.1 Contact resistance 接触阻抗	Being measured at 1 KHz small current contact resistance meter. 在 1kHz 小电流下测量。	20mΩ max. 20 毫欧 以下。
5.2 Insulation resistance 绝缘阻抗	Measurements shall be made following application of DC 500 V potential across terminals and across terminals and frame for 1 minute. 在端子之间和端子与壳之间加 DC 500 V 条件下,持续 1 分钟测量。	100MΩ min. 100 兆欧 以上。
5.3 Withstand voltage 耐电压	AC 250 V(50Hz or 60 Hz)shall be applied across terminals and across terminals and frame for one minute. 在端子之间和端子与壳之间加 AC 250 V (50Hz 或 60Hz)条件下,持续 1 分钟测量。	There shall be no breakdown 无击穿现象出现.

6. Mechanical performance 机械性能

6.1	Contact force 接触压力	1mm compression 用工具压簧片(单片)1.95mm,测量压力。	contact force: 0.6~1.6N
6.2	Range 使用温度范围	Operation temperature 在-40~+85°C温度内使用	

7. Durability 耐久性

7.1	Lift test 寿命试验	5,000 cycles of operation at a rate of 10-20 cycles per minute with unloading 在无负载条件下,以每分钟 10-20 次的速度操作 10,000 次。	(1) Contact resistance 接触阻抗 100m Ω max.100 毫欧 以下 (2) 其它满足机械,电气性能.
7.2	Heat test 耐热试验	85±3°C for 96 hours, test after keeping in normal condition for 60 minutes. 在 85±3°C 环境中放 96 小时,再放在正常环境中,60 分钟后进行测试。	Insulation resistance 50M Ω min. 50 兆欧以上,其它满足机械,电气性能.

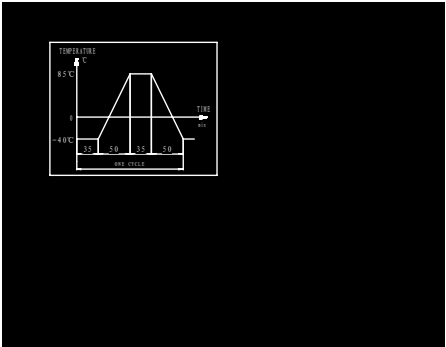
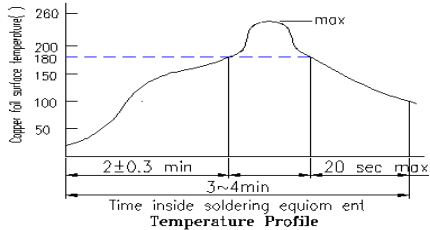
7.3	Humidity test 耐湿试验	40 ± 3 °C 90-95%RH for 96 hours, test after keeping in normal condition for 60 min. 在 40 ± 3 °C 90—95%RH 环境中放 96 小时, 再放在正常环境中, 60 分钟后进行测试。	Insulation resistance 50MΩ min. 50 兆欧以上, 其它满足机械, 电气性能.
7.4	Cold test 耐冷试验	At -40 ± 3 °C for 96 hours, test after keeping in normal condition for 30 min. 在 -40 ± 3 °C 环境中放 96 小时, 再放在正常环境中, 30 分钟后进行测试。	There shall be no sign of damage mechanically and electrically 无任何迹象显示机械及电气性能损坏。
7.5	Temperature cycling test 温度交变试验	In FIG. For 5 cycles, test after keeping in normal condition for 60 min. 如图示之环境中, 循环 5 次后, 再置于正常环境中, 60 分钟后进行测试。 	Insulation resistance 50MΩ min. 50 兆欧以上, 其它满足机械, 电气性能.
7.6	Soldering test 可焊性试验	The sort of dip solder terminal: The foot of the spring shall be dipped 2mm in the solder bath at a temperature of 230 ± 5 °C for 3 ± 0.5 sec. 将簧片焊脚部浸入焊锡池 2mm 深, 温度 230 ± 5 °C 时间 3 ± 0.5 秒。	A new uniform coating of solder shall cover a minimum of 95% of the surface being immersed. 浸入部分 95% 以上表面被锡覆盖。
7.5	Resistance to soldering heat test 耐焊性试验	Reflow Soldering Conditions: Preheat: Temperature on the copper foil surface should reach 180 °C. 2 ± 0.3 minutes after the P.W.B entered into the soldering equipment. Soldering heat: Temperature on the copper foil surface should reach the peak temperature of 260 °C with in 10 seconds after the P.W.B enter into soldering heat zone. 过回流焊条件: 预热: 电镀层表面的温度应达到 180 °C, 2 ± 0.3 分钟, 后电路板进入回流焊设备. 回流焊温度: 电镀层表面温度最高为 260 °C 且停留不超过 10 秒后电路板进入低温焊接处。 	Without deformation of case or excessive looseness of terminals electrical characteristics shall be satisfied. 本体无变形, 能满足于机械、电气性能。
8.	Others	When the amendment of this specification comes into necessity, the amendment must be made by the mutual consultation and agreement between manufacturer and customer. 当规格书需要修正时, 需客户同厂方共同确认	